

AS 1170.2 - CERTIFICATION FOR 4m HINGED LIGHT POLE

SAFE WIND VELOCITY: 26 m/s

Wind Velocity Region: N2 Region for maximum of 25° Angle of Solar Panel and N1 Region for maximum 30° Angle of Solar Panel

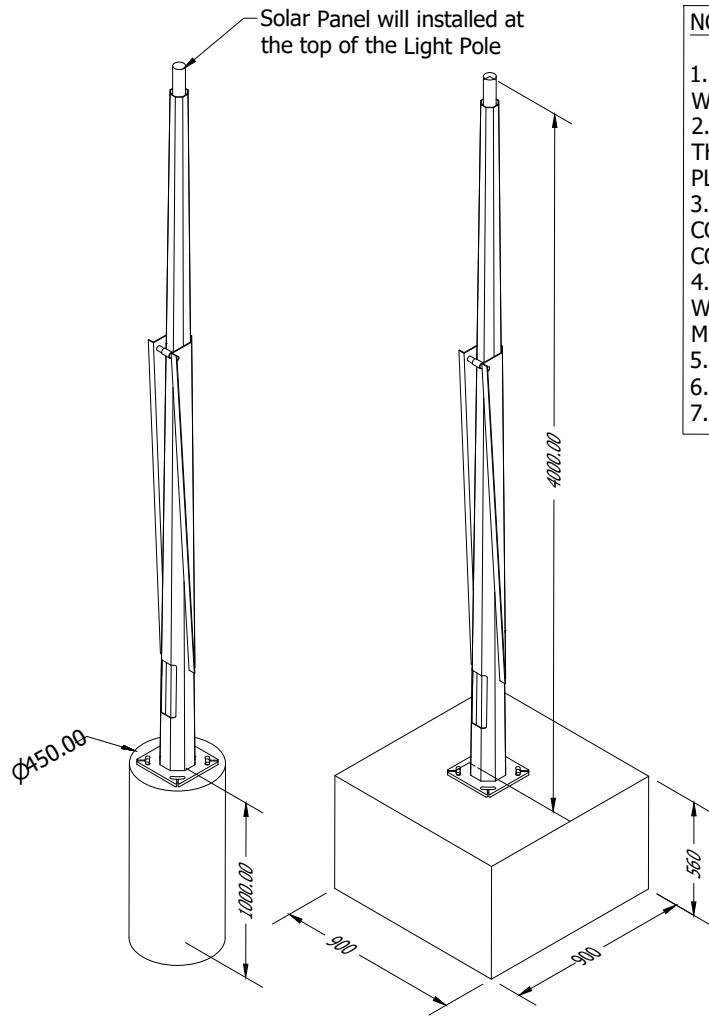

Configuration 1
SCALE 1/25

Configuration 2
SCALE 1/25

NOTES:

1. THE 4m HINGED LIGHT POLE IS RATED FOR WIND CONDITIONS IN N1 AND N2 REGIONS AT 26 m/s (93.6 km/hr). IT CAN WITHSTAND ULTIMATE PRESSURE OF UP TO 0.86 kPa AT A 25° SOLAR PANEL ANGLE AND 0.62 kPa AT A 30° SOLAR PANEL ANGLE.
2. ANALYSIS WAS PERFORMED BY CALCULATING WIND FORCES ACTING ON THE SOLAR PANEL AT VARIOUS ANGLES, APPLYING THEM TO THE TOP OF THE LIGHTING POLE, AND ALSO APPLYING WIND PRESSURE TO THE POLE ITSELF, WITH THE BOTTOM PLATE FIXED FOR CONFIGURATION 1 WHERE IT WILL BE ANCHORED TO THE FOUNDATION.
3. FOR THE FOUNDATION OF CONFIGURATION 1, THE BORED PIER IS A 1000 mm DEEP, 450 mm DIAMETER REINFORCED CONCRETE STRUCTURE WITH 4-N16 BARS AND R10 TIES AT 300 MM PITCH, ENCASED IN 25 MPa CONCRETE WITH A 50 mm COVER.
4. CALCULATIONS WERE ALSO PERFORMED TO ANALYZE THE LIGHTING POLE AGAINST THE OVERTURNING MOMENT CREATED BY WIND FORCES ACTING ON THE SOLAR PANEL FOR CONFIGURATION 2, WHERE THE POLE IS FIXED ON A CONCRETE BLOCK MEASURING 900mm X 900mm X 560mm AND WEIGHING 1000 kg.
5. WELDING AS PER AS1554 (SP Weld).
6. The M24 J BOLT GRADE 8.8 ANCHOR IS SAFE FOR USE AND TO BE INSTALLED AS PER ANUFACTURER SPECIFICATIONS.
7. ALL DIMENSIONS ARE IN mm.

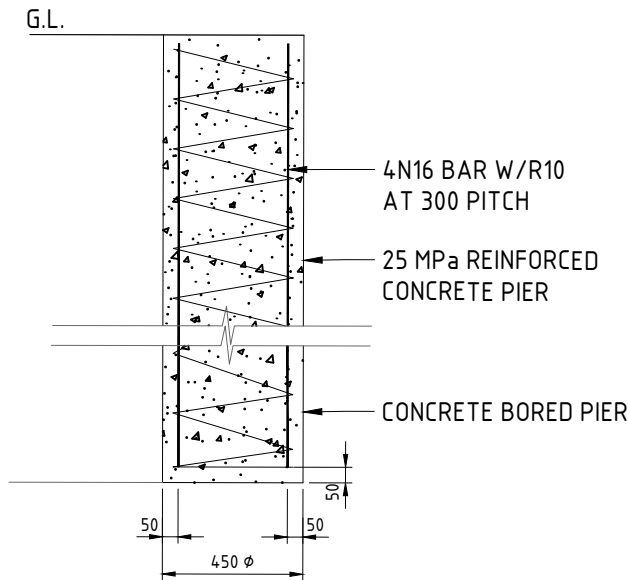

BORED PIER DETAILS

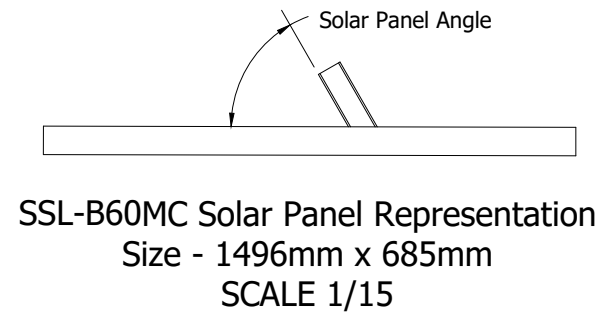

Safe Wind Speeds for Varying Solar Panel Angles	
Solar Panel Angle	Safe Wind Velocity (kmph)
upto 25°	93.6 (N2 Region)
25° to 30°	93.6 (N1 Region)
30° to 35°	65
35° to 45°	60
45° to 60°	55



REVISION	DATE	REVISED BY	DRAWN	APPROVED	OWNED BY	DESCRIPTION	SHEET TITLE	CREATED BY
A	23/08/2024	MD	V.K	N.S.		4m Hinged Light Pole	4m Hinged Light Pole Wind Rating Certification	 www.csaengineering.com.au
B	02/02/2026	G.V.S	DESIGNED	RPEQ No.:				
C	11/05/2026	J.B	V.K	23862				
			SHEET No.:					
			32123_1					

AS 1170.2 - CERTIFICATION FOR 4m HINGED LIGHT POLE

SAFE WIND VELOCITY: 26 m/s

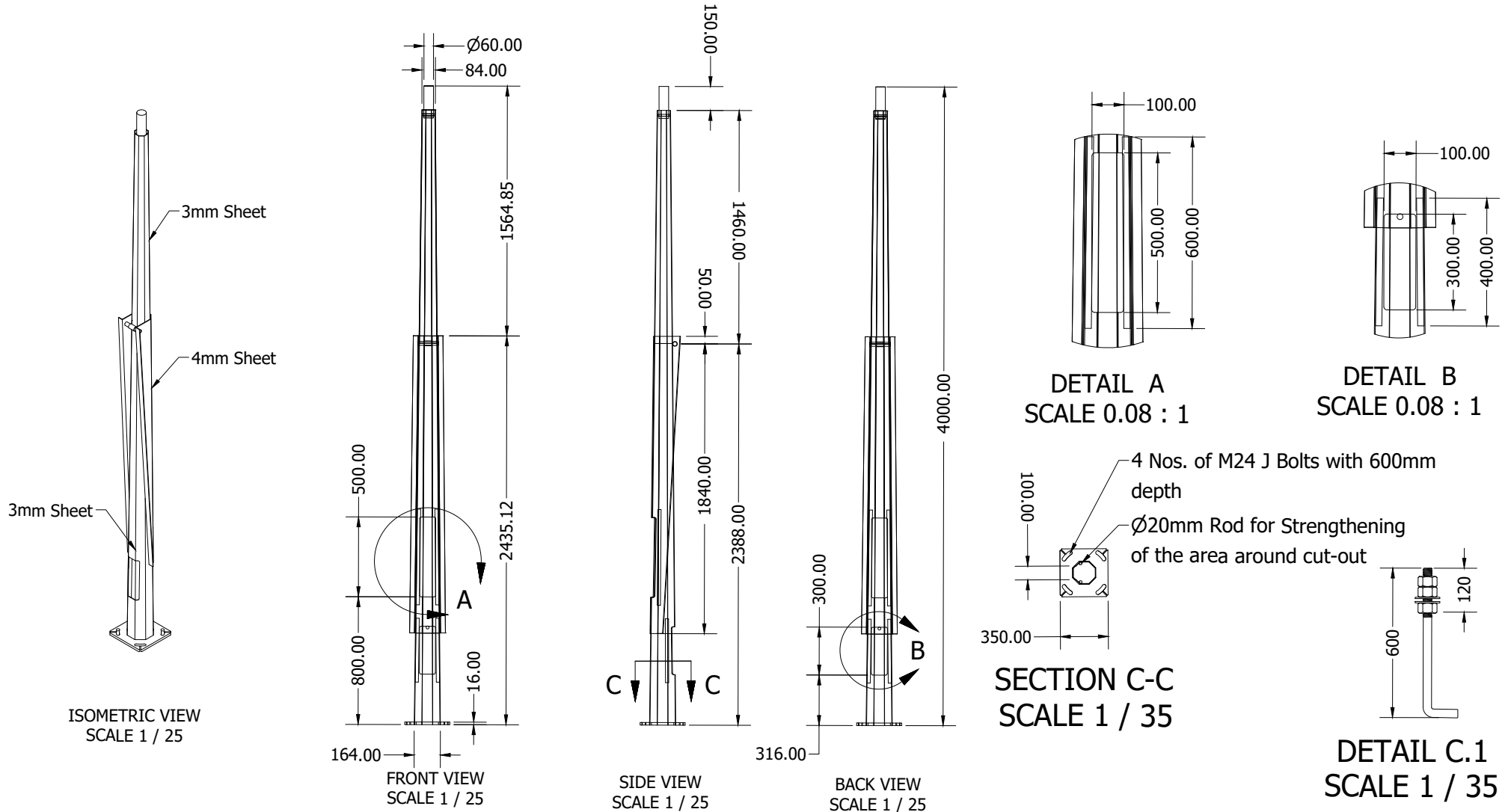
Wind Velocity Region: N2 Region for maximum of 25° Angle of Solar Panel and N1 Region for maximum 30° Angle of Solar Panel



REVISION	DATE	REVISED BY	DRAWN	APPROVED	OWNED BY	DESCRIPTION	SHEET TITLE	CREATED BY
A	23/08/2024	MD	V.K	N.S.		4m Hinged Light Pole	4m Hinged Light Pole Wind Rating Certification	 www.csaengineering.com.au
B	02/02/2026	G.V.S	DESIGNED	RPEQ No.:				
C	11/05/2026	J.B	V.K	23862				
			SHEET No.:					
			32123_2					

AS 1170.2 - CERTIFICATION FOR 4m HINGED LIGHT POLE

SAFE WIND VELOCITY: 26 m/s

Wind Velocity Region: N2 Region for maximum of 25° Angle of Solar Panel and N1 Region for maximum 30° Angle of Solar Panel

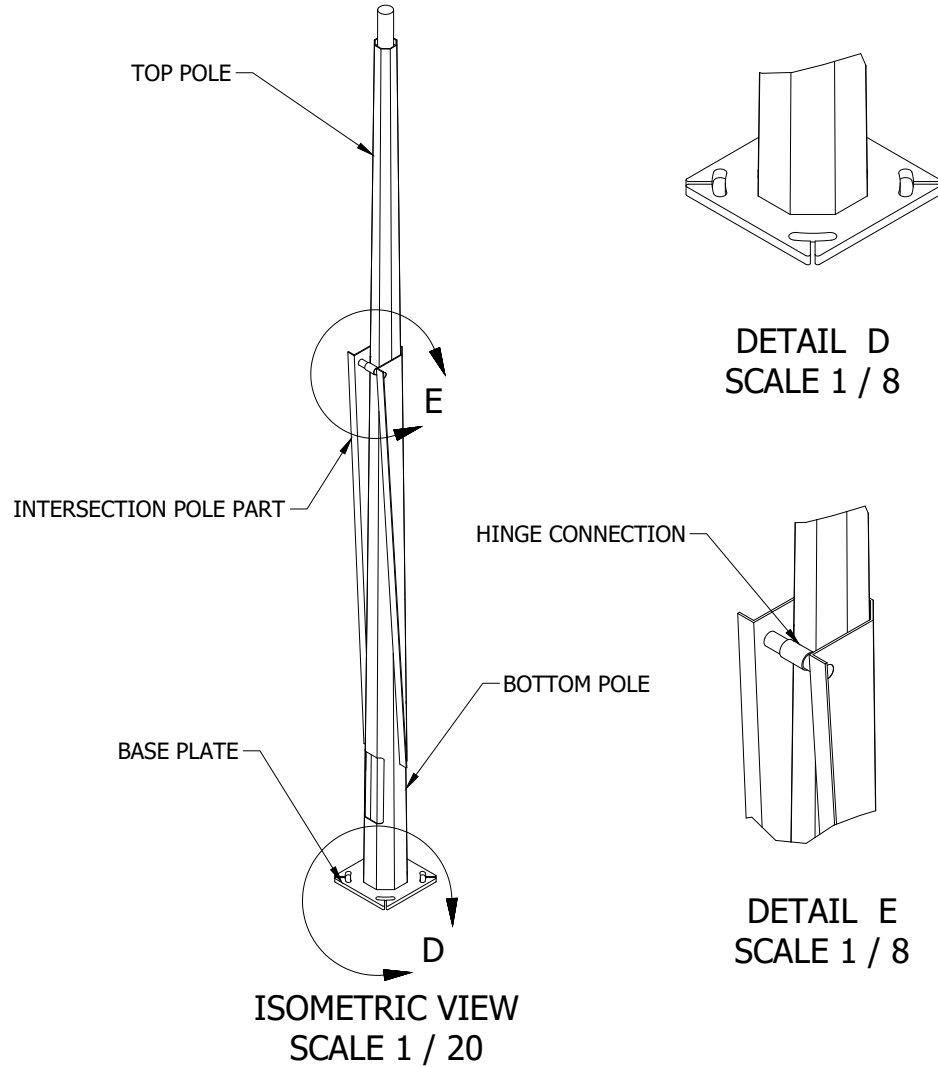

SPECIFICATIONS				
PART NAME	MATERIAL	TOTAL LENGTH	QTY	WEIGHT IN KG/QTY
TOP POLE	Q 355	2390	1	10.9
BOTTOM POLE	Q 355	1460	1	25.36
INTERSECTION POLE PART	Q 355	1890	1	23.39
BOTTOM PLATE	Q 355	282	1	6.32

SAFETY INSTRUCTIONS:

- BEFORE INSTALLATION, ASSESS THE SITE FOR ANY POTENTIAL HAZARDS, SUCH AS OVERHEAD POWER LINES, UNSTABLE GROUND, OR NEARBY STRUCTURES. ENSURE THAT THE SITE IS SUITABLE FOR THE POLE'S HEIGHT AND DESIGN.
- ENSURE THE BASE PLATE IS SECURELY ANCHORED INTO THE FOUNDATION. USE BOLTS AND NUTS SPECIFIED BY THE DESIGN, AND TIGHTEN THEM TO THE RECOMMENDED TORQUE SETTINGS. THE FOUNDATION MUST BE LEVEL AND STABLE TO AVOID TILTING OR UNEVEN STRESS DISTRIBUTION.
- THE HINGE MECHANISM MUST BE ROBUST AND DESIGNED TO PREVENT FAILURE UNDER THE APPLIED LOADS. IT SHOULD ALLOW SAFE AND EASY LOWERING AND RAISING OF THE POLE WITHOUT EXCESSIVE PLAY OR DEFORMATION.
- PERSONAL ITEMS AND OTHER EQUIPMENT ARE NOT ALLOWED IN THE FALL ZONE.
- THE POLE IS DESIGNED TO WITHSTAND A WIND VELOCITY OF UP TO 26 m/s (93.6 km/hr) AS PER AS 4055 AND AS 1170.2 FOR THE N1 AND N2 REGION. DO NOT INSTALL THE POLE IN AREAS WHERE HIGHER WIND SPEEDS ARE EXPECTED UNLESS FURTHER ANALYSIS AND REINFORCEMENT ARE PERFORMED.
- SAFETY PRECAUTIONS MUST BE IMPLEMENTED BY THE INSPECTOR FOR SPEEDS EXCEEDING 93.6 km/hr.
- AFTER RAISING THE POLE, ENSURE THE LOCKING MECHANISM IS SECURELY ENGAGED TO PREVENT THE POLE FROM ACCIDENTALLY LOWERING, ESPECIALLY UNDER WINDY CONDITIONS.
- PERFORM REGULAR INSPECTIONS OF THE POLE, HINGE MECHANISM, AND BASE PLATE FOR SIGNS OF CORROSION, WEAR, OR DAMAGE. CHECK FOR ANY LOOSE BOLTS OR OTHER COMPONENTS THAT MAY HAVE BEEN AFFECTED BY WIND OR ENVIRONMENTAL CONDITIONS.
- WHEN THE POLE IS BEING LOWERED OR RAISED, KEEP NON-ESSENTIAL PERSONNEL AND BYSTANDERS OUT OF THE AREA TO PREVENT ACCIDENTS.
- INSTALL AN IDENTIFICATION PLATE ON THE POLE THAT INCLUDES THE MODEL NUMBER, WIND RATING, MANUFACTURER'S DETAILS, INSTALLATION DATE, SIZE, AND ANY OTHER RELEVANT SPECIFICATIONS FOR IDENTIFICATION AND COMPLIANCE.

REVISION	DATE	REVISED BY	DRAWN	APPROVED	OWNED BY	DESCRIPTION	SHEET TITLE	CREATED BY
A	23/08/2024	MD	V.K	N.S.		4m Hinged Light Pole	4m Hinged Light Pole Wind Rating Certification	 www.csaengineering.com.au
B	02/02/2026	G.V.S	DESIGNED	RPEQ No.:				
C	11/05/2026	J.B	V.K	23862				
			SHEET No.:					
			32123_3					